

# A9 Waterproof connector

## Applications:

- E-Bike
- E-Scooter
- Drone
- Vacuum Cleaner
- Energy storage battery
- electric lawn mower
- AGV

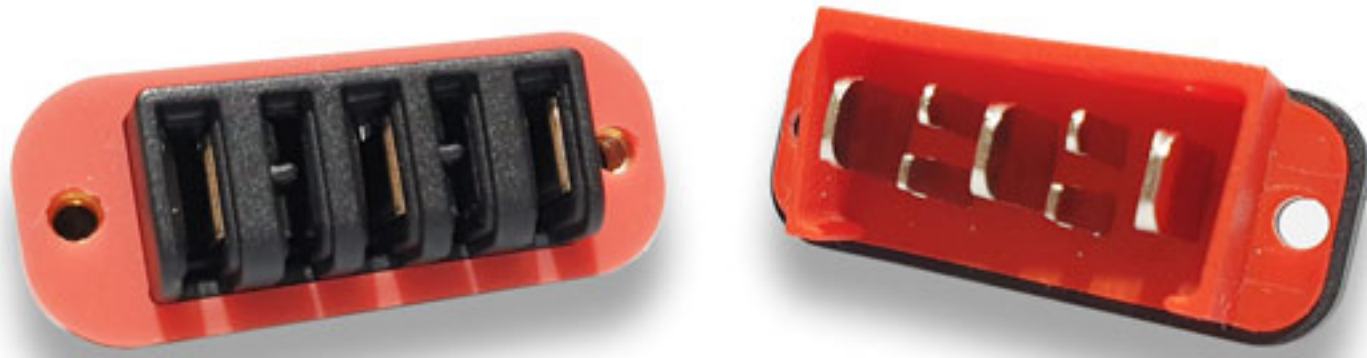

### Male Connector

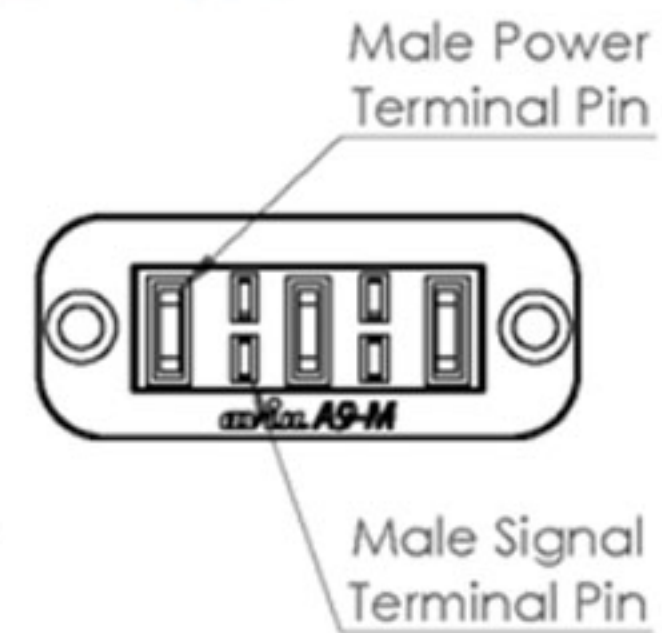
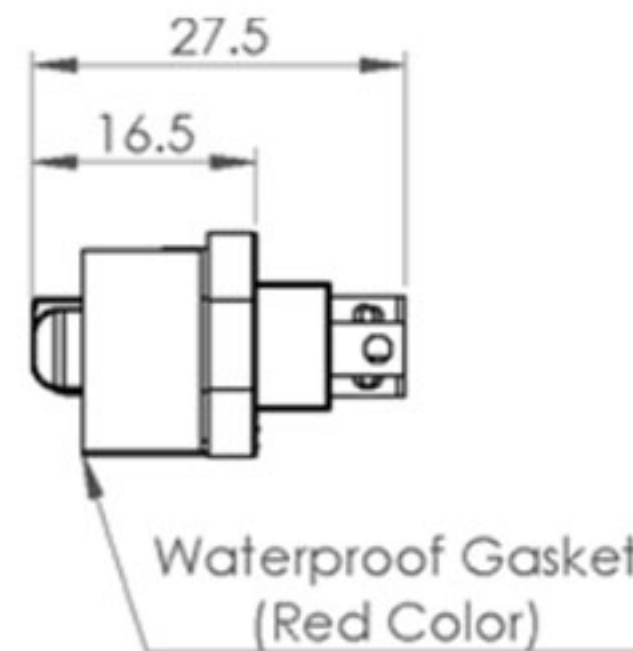
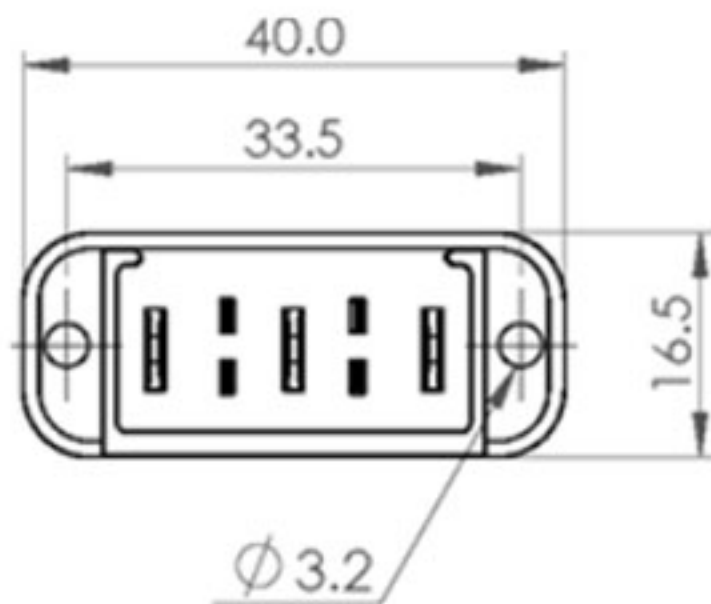

### Female Connector

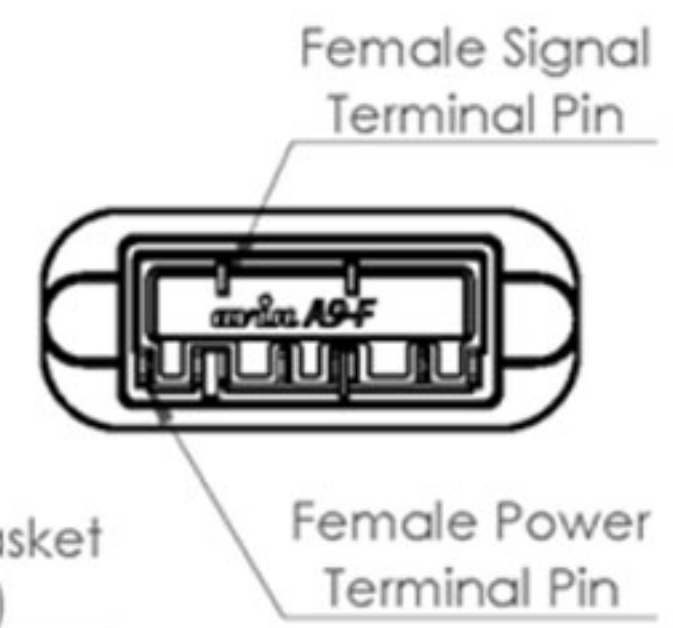
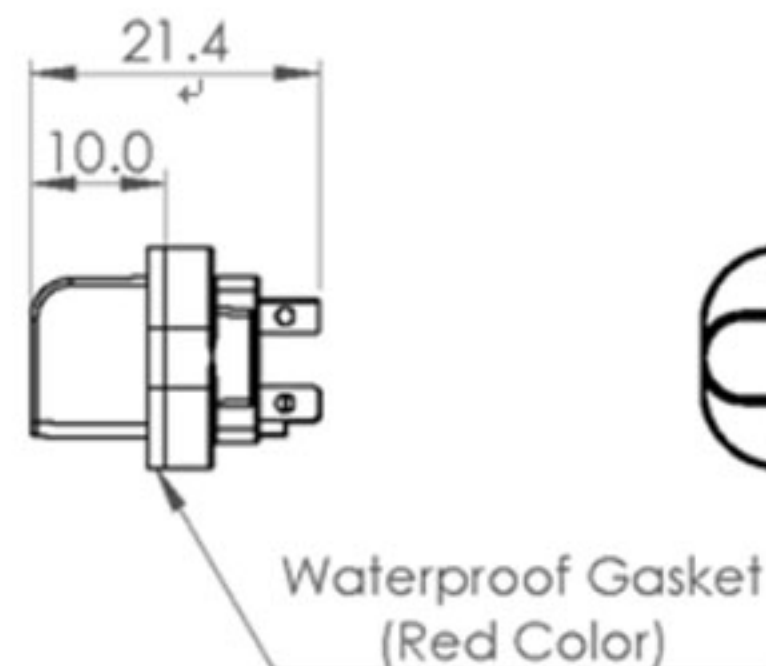
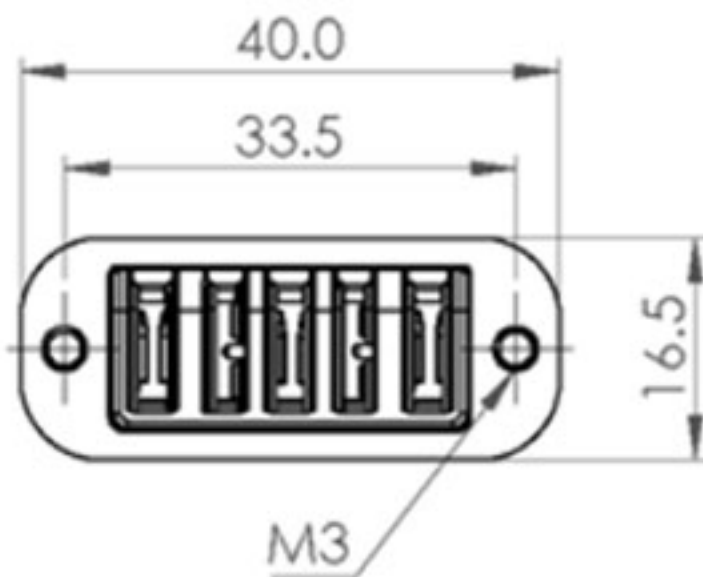

### Features

Terminal	3 PWR. pin & 4 SIG. pin
	PWR.Terminal 25A
Current withstand	(Instantaneous peak current 30A)
	Signal terminal 2-5A
IP rating	IP66
Material of housing	PBT+GF15% UL94 V0

### Wire Information

Wire Spec. for Standard Sample	
Wire Gauge	
Power Terminal	10AWG
Signal Terminal	24AWG to 22AWG